

HILINE

4-page web offset press

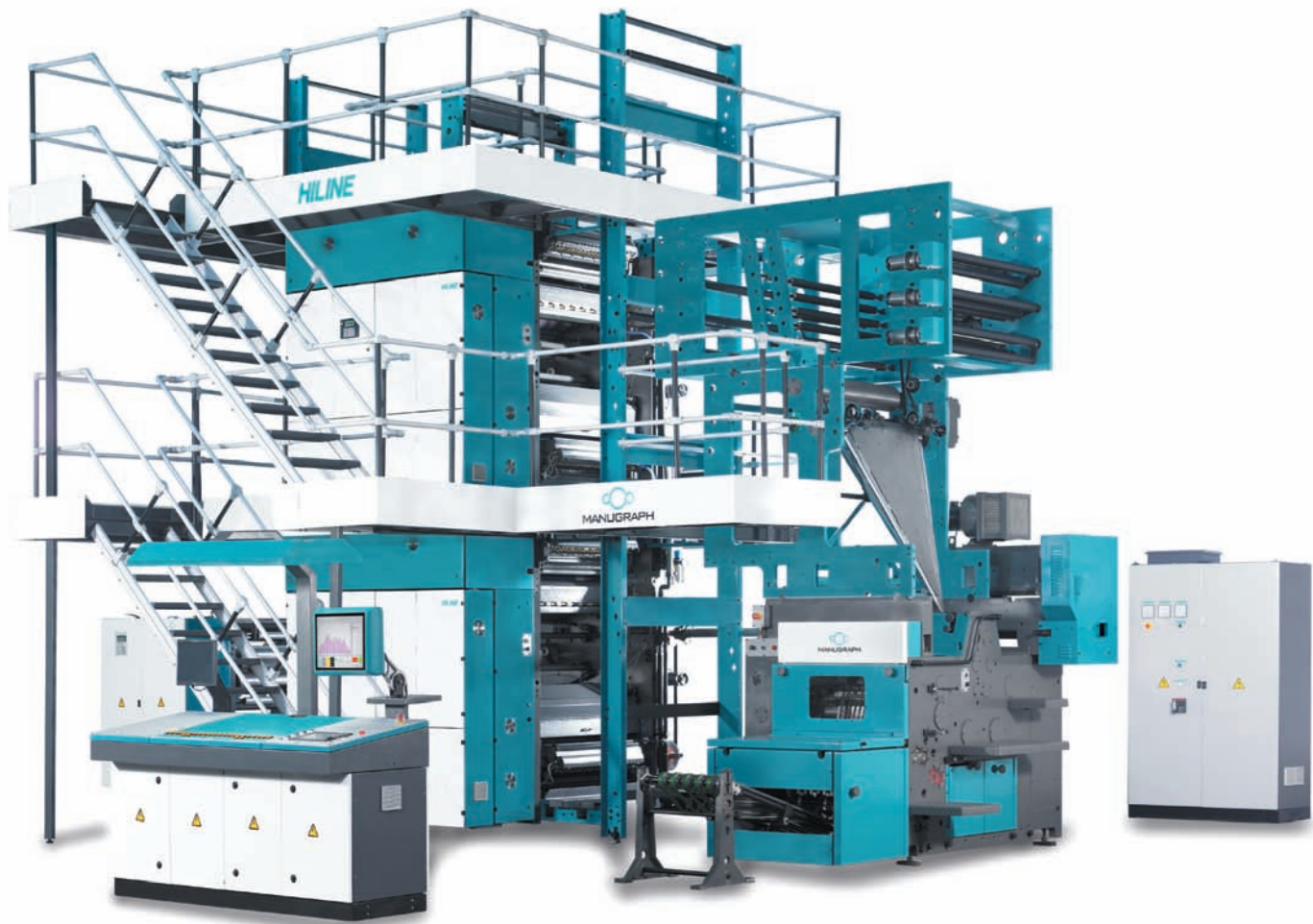

MANUGRAPH

Technology in Print

HILINE: An efficient press for meeting various printing requirements

Flexibility is the keynote behind the concept of Hiline. Based on modular designs, Hiline is an economic model that meets the printing requirements of medium circulation newspapers efficiently. A maximum output of 45,000 copies an hour with an excellent price performance ratio, its short make ready and changeover

time, flexibility and the right level of automation, translate to high levels of productivity, most cost effectively.

Hiline is operator friendly and easy to maintain - the two most important factors for economic and efficient production.

HILINE Tower features at a glance

- 50,000 copies per hour.
- Standalone flying splicer.
- PIV driven Tension roller with rubber roller nip.
- Toolless plate lock-up.
- Pneumatics for impression, inking/dampening and reel stand brakes.
- Motorised bearer lubrication
- Remote registration and cut off control.
- Motorised dustle wheel control.
- 9-roller inking system with two forme rollers of different diameters.
- 4-roller brush dampening system.
- Auto tracking of ink duct and water pan roller.
- Web severer at the entry & exit of tower.
- Inertia roller at the tower exit to automatically pull out and wrap up the paper upon web breaks.
- Infrared web break detectors at entry and exit of Tower.
- Variable speed RTF roller.
- Ink silencing system for each ink train.
- Shaftless or shafted drive systems.
- Overload protection: Clutch control for shafted presslines and electronic control for shaftless presslines.
- Pneumatic ON-OFF controls for washing device.
- Integrated PLC panel on print unit.
- Choice of jaw folders: F 222/1240/233.
- PLC based electrical control system.
- ManuColor remote ink zone control system. Option of CIP3 interface / TIFF 1-Bit connectivity.

Creating a world of possibilities:

Modular unit designs

The tower units are of robust construction with box type sidewalls on drive side and plain side wall on operating side and are made of high strength cast iron with ribbed construction. A wide range of unit designs satisfies all requirements of color placement, leading to total flexibility. The space saving design of Hiline with its reduced tower width and the high quality components that go into its manufacture are the hallmarks of the machine.

Printing units are available in H modules with vertical web lead. The 4-high tower comprises 2 H units placed one over the other. This offers high color and page

capacities predominantly for newspapers. PLC based electrical controls simplify operation and increase reliability.

Hiline incorporates precisely manufactured gears, world-class bearings and technologies that guarantee constant web tension and perfect registration at top speed. Such features, complemented by short web leads, ensure consistent unit-to-unit registration.

Criteria for selection of your Hiline print unit modules:

Mix and Match

If color pagination is high and back to back 4 color is a requirement, Tower configuration with its vertical web lead is the most ideal solution. Tower configuration of Hiline is supported by reliable tension control system, short web paths and anti fan out devices ensuring perfect register. While the Arch module from H unit frame would be suitable for mono color back to back, the H module could either be used for printing 2 webs with mono back to back, or a single web with 2 colors back to back. With a 3 high tower, even 3 webs can be

run back to back mono. Web tension control is precise and perfect on Hiline irrespective of the configuration and the web lengths. Should the color requirement however be restricted to one side, a couple of Y-type units would be most suitable and cost effective. And for purely mono work, I-type unit could be chosen. The overriding advantage of the I & Y-type units is the integrated reel splicers with its space saving design.

But the best thing about the Hiline is the ability to mix different print unit modules in a single pressline to best suit the specific requirements and space availability -truly Mix & Match !

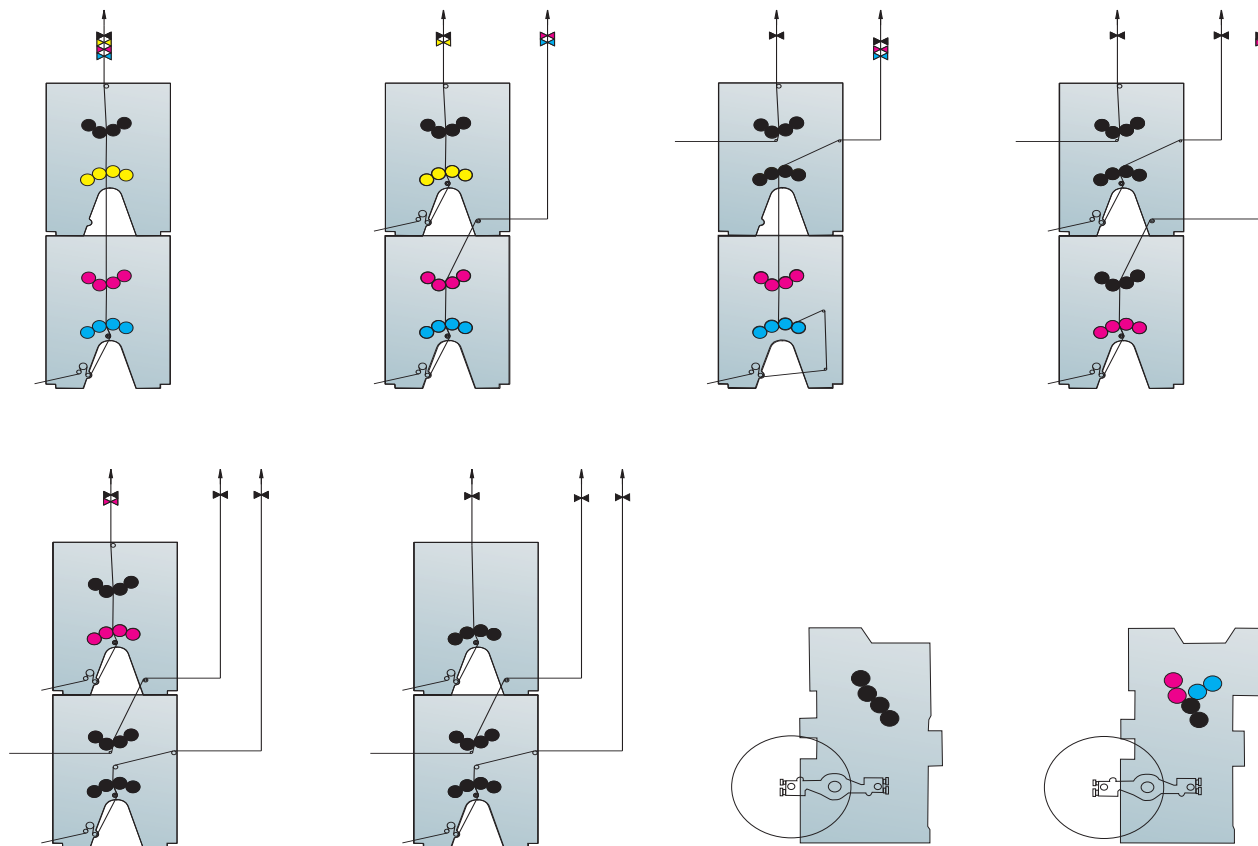

Combination of different module types for high flexibility

Cylinders for the best performance

The dynamically balanced plate and blanket cylinders are made of solid stainless steel and mounted on pre-loaded bearings. All cylinders have wide and strong bearer rings made of tool steel. The bearers are automatically lubricated.

Plate cylinders have a narrow-slot toolless plate lock-up system, and blanket cylinders have worm and worm wheel type clamping system for quick mounting of blankets. The plate lock-up design facilitates fast and easy plate changes. Register wedge provided in the cylinders ensures quick plate lock-up in true register. Adjustment to circumferential and lateral register is motorized.

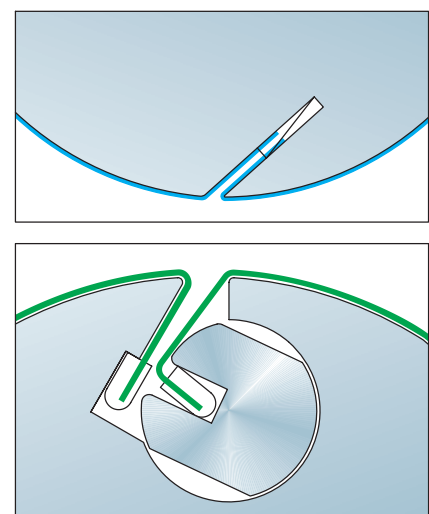

Sturdy Drive System

Hiline sports a sturdy drive system. There is a choice of press drive systems: shafted and shaftless. On a conventional drive system, all units are mechanically synchronized with the line shaft. The drive shaft is outside the sidewall and through a compact gear box. The engage/disengage operation is via pneumatic clutch with built-in overload protection. In the shaftless

drive system, each H unit has its own AC asynchronous servomotor and drive control, with built-in overload protection. All motors are electronically synchronized. Drive and electronic components are housed in separate drive panels. Shaftless drives for each stack are also available optionally.

Inking System

The inking system consists of a 9 roller ink train with 2 forme rollers of differing diameters and 2 Rilsan coated rollers with an oscillation stroke of 30 mm .The large diameter ink forme rollers, complimented by a large diameter oscillating roller and ink ductor roller means finer, smoother and precise ink lays on the plate. The ink rollers are strong and stable being shafted with bearings inside. The roller bracket levers are made of steel with fine-pitched screws. And the roller on-off setting system employs double- acting pneumatic cylinder, making settings very simple and positive.

A separate DC motor having auto tracking facility with the press speed drives the ink duct roller .The speed of the ink duct roller can be varied from the central console or from individual print units .The ink duct has an undershot blade with 22 keys for zonewise regulation of ink .The ink fountain roller transfers the ink to a film roller from where the ink take up roller picks up and transfers it to the other rollers of the ink train .Ink train silencing is available for every Ink train. Each Ink train has pneumatically operated washing device.

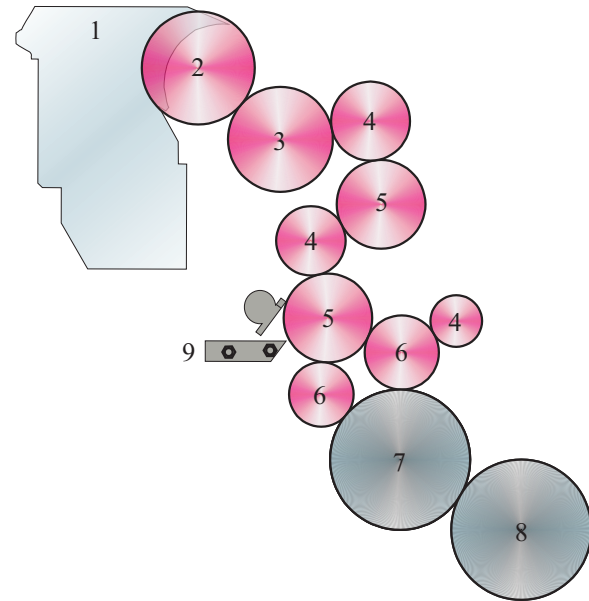

- | | |
|--------------------------|-----------------------|
| 1. Ink duct | 2. Duct Roller |
| 3. Film roller | 4. Distributor roller |
| 5. Oscillating roller | 6. Forme roller |
| 7. Plate cylinder | 8. Blanket cylinder |
| 9. Roller washing device | |

Dampening System

The dampening system is a four roller non contact brush dampening system .The spiral brush rotates at a constant speed .The pan roller is driven by a separate variable speed DC motor and automatically tracks the press speed .Three different pre programmed speed curves are available for selection for pan roller tracking . Operators can also define their own curve suitable for the job .The speed of the pan roller can be set & varied from either the central console or from the individual print unit .Width wise dampener flaps are provided to prevent spraying on unwanted areas . Centralised dampener tank with chilling facility and level sensors is provided . Chilled dampening solution maintains ink

temperature , which minimizes ink consumption and reduces ink problems .

- | | |
|-----------------------|------------------------|
| 1. Pan roller | 2. Spiral Brush roller |
| 3. Oscillating roller | 4. Forme roller |
| 5. Plate cylinder | 6. Blanket cylinder |

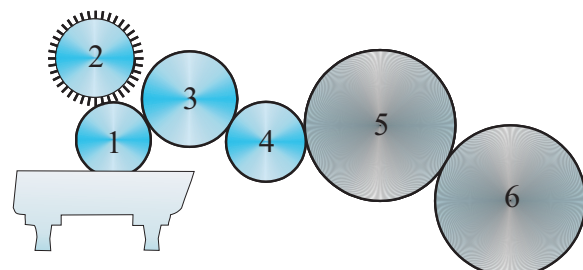

Folder flexibility for more product versatility

Hiline offers a choice of 3 rigid folders to suit different product requirements. The standard folder F222 is designed for 6 webs on 2 2 2 principle and delivers 24 pages broadsheet or 48 pages tabloid. For a higher number of webs, a F233 jaw folder based on 2:3:3 principle or F1240 is offered. The F233 & F1240 folders can take a maximum of 12 webs i.e. a maximum of 48 pages broadsheet or 96 pages tabloid. The F233 & F1240 folders have been specifically designed to provide the necessary folding precision for high pagination product.

There are motorized cut-off compensating rollers on the folder superstructure for every web.

The folders can be offered with optionals like 3rd fold (quarter), parallel fold, and balloon formers. Gluing and stitching attachment also can be offered on F233 & F1240 folders.



F222

Features

- F222, F233 or F1240 rigid jaw folders, for up to 12 webs.
- Variable speed drive on RTF.
- Air cushioned 70° former.
- One or two upper formers for 2 or 3 section products.
- Lap adjustment facility.
- Folding cylinder with diameter increment facility.
- Slitter mechanism for tabloid production.
- Web severer in the folder.
- Electronic multi sheet detection facility.
- Adjustable batch counter.
- Optional attachments :
 - Rotary 3rd (quarter) fold.
 - Double parallel fold for F222 and F233.
 - Longitudinal and cross perforation
 - Facilities for gluing stitching on F233 & 1240 folders.

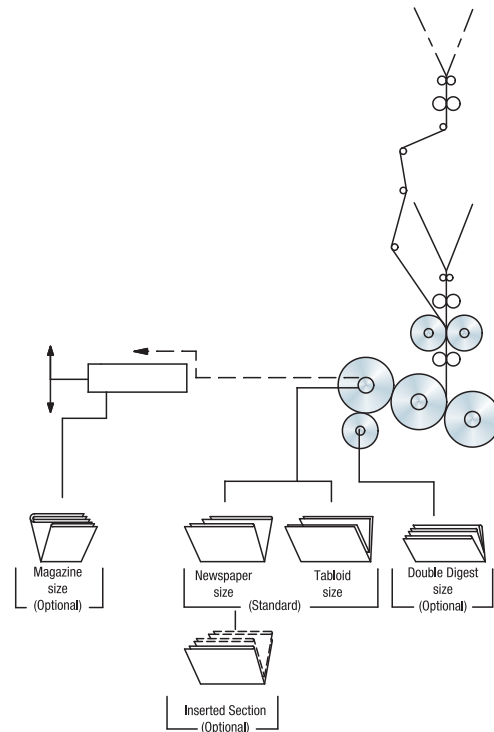

Folding possibilities on a F222 folder

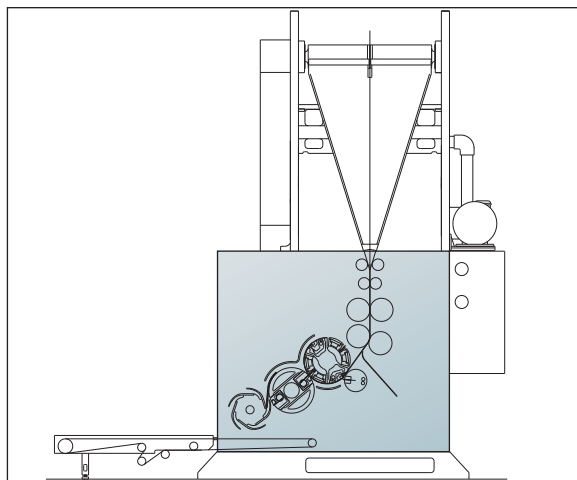

F 1240

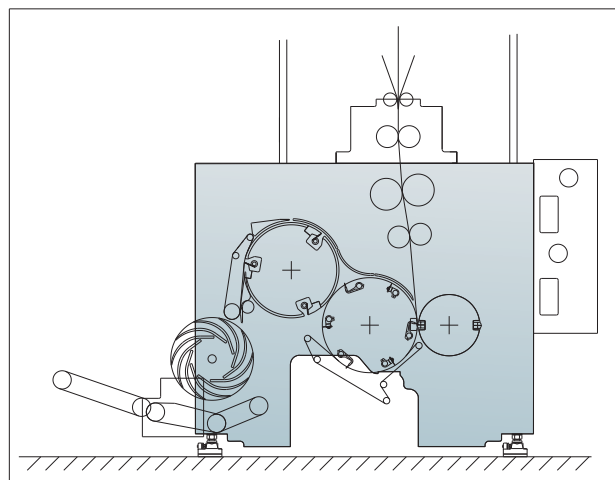

F 233

Reliable Flying Splicers

Hiline offers a choice of flying splicers for their towers. Depending on the reel holding capacity requirement, the right splicer is configured with the pressline. The splicers can be placed inline or at right angles or even at substructure level. I & Y Print units have dedicated, compact integrated flying splicer for optimum space utilization.

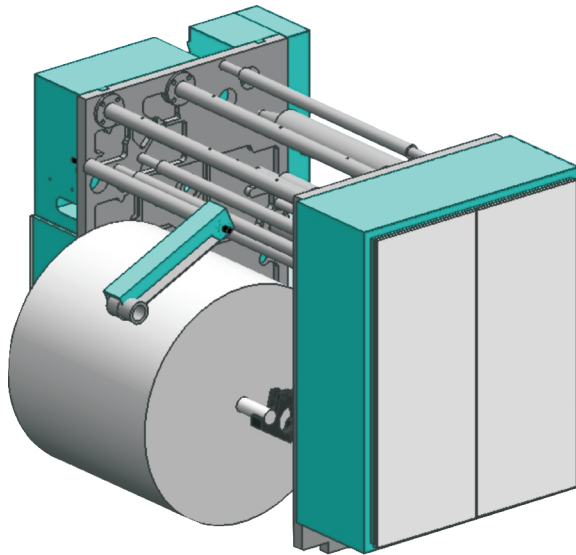

AP 4542

Technical Specifications

Reel diameter	max. 1067 mm (42")
Web width	915 mm
Core diameter	76 mm
Reel weight	max. 650 Kg
Web speed	max. 7.22 m/sec

Standard features

- Two arm reel splicer capable of holding 42" dia. reel
- Hydraulic or mechanical web trolley for reel loading
- Pneumatically expandable reel clamping shaft
- Belt for accelerating new reel
- Dancing roller with precision pneumatic control for close loop tension
- Load cell-based tension monitoring system
- Inline, 90° placement or at basement
- Basement and 90° placement pasters come with motorised lateral reel shifting.
- Local Control panel with Touch control, Display screen and Diagnostics

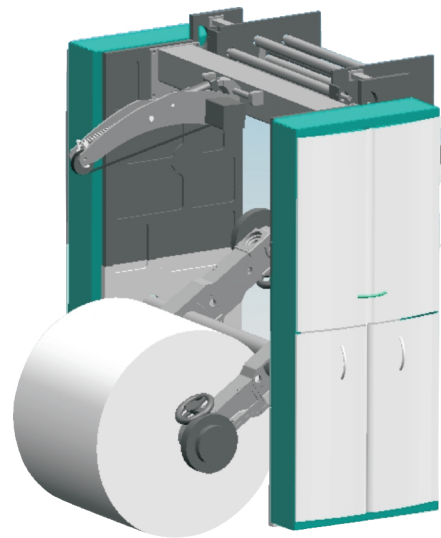

AP 6050

Technical Specifications

Reel diameter	max. 1270 mm (50")
Web width	965 mm
Core diameter	76 mm
Reel weight	max. 1200 Kg
Web speed	max. 11 m/Sec

Standard features

- Two arm reel splicer capable of holding two full size 50 dia. reels
- Reel loading possible directly from floor
- Reel holding on pneumatically activated lock-up cones, no reel shaft needed
- Motorized accelerating belt for new reel
- Dancing roller with precision electro-pneumatics for close-loop tension and monitoring
- Reel carrying arms with motorized pivoting
- Motorized lateral individual adjustment
- Automatic reel edge alignment before pasting
- Local control panel with touch control, display screen and diagnostics
- Inline, 90° placement or at basement

Total Control

Electricals, Operating Controls and Drive



All electricals are pre-wired and networked with remote programmable logic controller system. This means less cable route, easy diagnostics and trouble shooting, user friendliness and quick access to individual print units.

Press controls

Basic level module

Each unit and auto paster has its own PLC for all print functions and splicing applications. The touch panel offer different print functions, which are reflected on the central console display as well. At the print unit level, engagement of ink duct and water pan roller, adjustment of ink water balance, engagement of inking & dampening rollers, manual adjustment of ink keys and web break-detector selections are all possible.

Central Console & PLC

There is high speed network for control between central console and towers. The Central Console has operating switches for all press drive functions, It also has a color touch screen operator interface from where all print units can be accessed and functions controlled, in both auto and manual mode. Each H stack can be engaged/

disengaged from the central console. Functions such as dampener & ink roller speed adjustment and preprogrammed ink and water balance settings can be easily achieved from the touch screen. Basic data such as machine speed, gross copy, net copy, stack functional status are all displayed on the touch screen. The motorized registration, and bustle wheel adjustments are remotely controlled from the touch screen. Fault diagnostics and periodic maintenance guidelines are also displayed. And, optionally all press and register controls can also be integrated with ManuColor, the remote ink control system from Manugraph.

MANUCOLOR REMOTE INK ZONE CONTROL

ManuColor Remote Ink Zone Control System is developed by Manugraph. It is a standalone system for remote ink zone control with option of CIP3 interface for ink key presetting. Multiple ManuColor Consoles can be configured based on configuration need.

- Separate 15 Inch Touch screen display for Remote Ink Zone Control
- Segmented Blade
- Job Storage
- Multi movement of motors
- Manual override
- Manual calibration
- Self diagnostics
- Individual ~~all~~ zone increase ~~decrease~~
- Locking of control keys
- Group zone increase/decrease
- Job saving ~~pre~~ setting
- Change of color order
- Editing notes

HILINE

Max. printing speed 2nd fold	50,000 c.p.h.		
Max. reel diameter :	AP 4542: 1067 mm (42 inches); AP 6050: 1270 mm (50 inches)		
Max. web width	915 mm (36 inches)		
Printing unit modules	H and 4 Hi Tower with vertical web leads, I type and Y type horizontal web leads		
Cut-off length	533, 546, 560, 578 mm (21, 21 ¹ / ₂ , 22, 22 ³ / ₄ inches)		
Plate mounting	Toolless slot mounting		
Flying Splicer / Autopaster	<ul style="list-style-type: none"> ● AP 4542 or AP 6050 for Tower ● Integrated paster for I/Y 		
Data management	PLC based		
Folder	F222	F233	F1240
Max No. of webs	6 webs / 45,000	12 webs / 50,000	12 webs / 50,000
Quarter Fold	4 webs / 30,000	6 webs / 40,000	8 webs / 35,000
Double parallel fold	2 webs / 30,000	5 webs / 40,000	No
Balloon Former	2 webs / 1 Balloon	4 webs / 2 Balloons	6 webs / 2 Balloons
Optionals	<ul style="list-style-type: none"> ● Shaftless drive ● Close loop registration & cut-off control system ● ManuColor remote ink zone control ● CIP3 Interface to ManuColor for Ink presetting ● Turner bar ● Bay window ● Spray Dampening 		

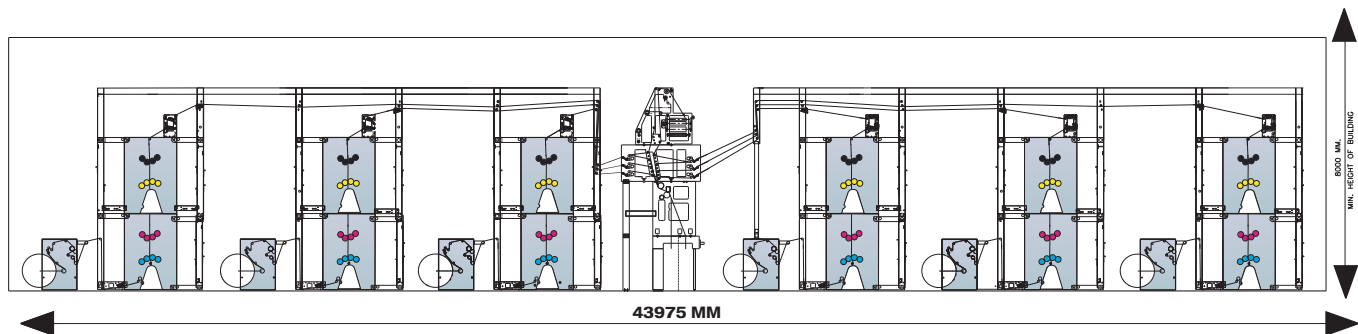

Manugraph India Ltd.

Sidhwa House, N.A. Sawant Marg, Colaba, Mumbai - 400 005 INDIA.
 Phone: +91 22 2287 4815/1191 Fax: +91 22 2287 0702
 E-mail: sales@manugraph.com Website: www.manugraph.com

Hiline is subject to continuous upgradation resulting from ongoing research and development and practical experiences gained. Therefore, in the interest of the customers we reserve the right to modify the specifications, features and technical data without notice. Only the specifications while confirming the order shall be binding. **HILINE** is a registered trademark of Manugraph India Ltd.